

Marvel-Schebler/Tillotson

Division Borg-Warner Corporation, 2195 South Elwin Road, Decatur, Illinois 62525

SERVICE BULLETIN

September 20, 1981

#A1-81

TO: All Registered Manual Holders

SUBJECT: Model HA Carburetor Float Shaft and Bracket Wear

CARBURETORS AFFECTED: All Model HA-6 Series carburetors except those with serial numbers as listed which incorporate this change:

Part Number	Serial Number
A10-5219	DE-7-1165 and up
A10-5224	DJ-4-134 and up
A10-5230	DH-3-613 and up
A10-5235	DG-3-580 and up
A10-5238	DK-0-159 and up
A10-5246	DI-4-166 and up
A10-5253	DL-3-966 and up
A10-5255	DP-3-110 and up
A10-5256	DO-4-204 and up
A10-5258	DQ-0-125 and up
A10-5261	DS-1-181 and up

*Ignore the center number, it is a factory control number only.

COMPLIANCE TIME: At next overhaul, or immediately if any of the following symptoms are experienced on Lycoming engines equipped with HA-6 carburetors that you are unable to correct with usual troubleshooting procedures.

- 1) Flooding Carburetor
- 2) Rough Engine at Low Throttle Settings
- 3) Inconsistent Engine Shutdown



FIGURE 1 shows this wear condition which has been noted in some carburetors.

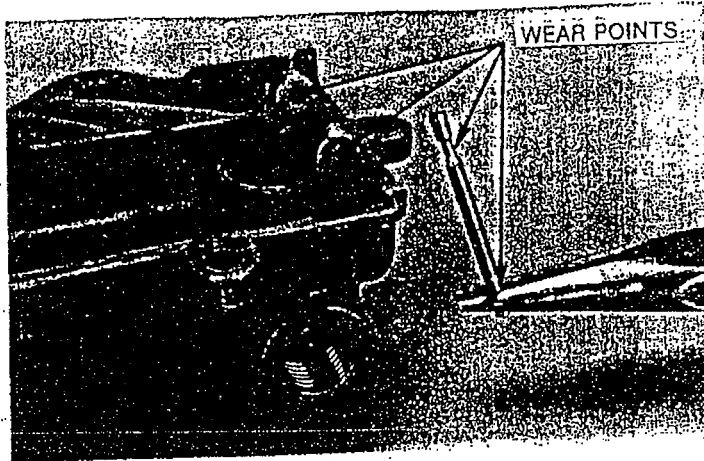

FIGURE 1

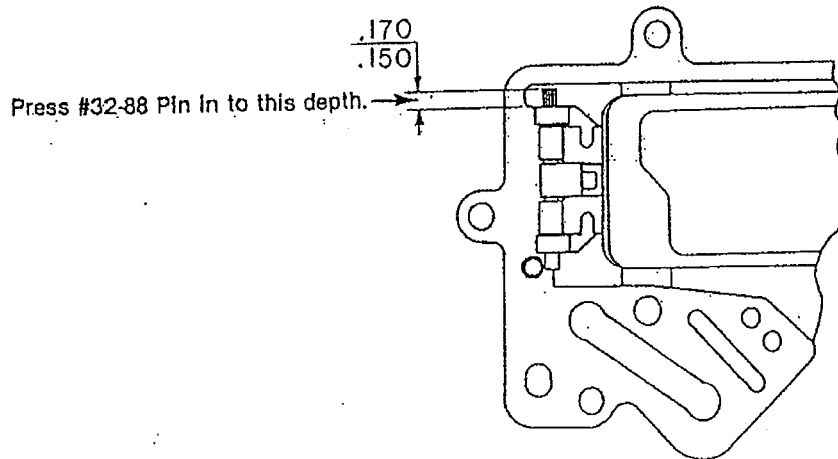

FIGURE 2

A kit can be obtained from your supplier to make the change to the new knurled pin. This kit is part number 666-824. It consists of the new knurled pin, the bowl cover gasket and 6 cover screw tab washers for re-safetying the carburetor.

Use a #30 drill blank as a gage to check wear limits of both holes. If the #30 drill blank will enter either hole the wear limits are exceeded, a new casting is required.

If during inspection a worn casting is detected, a new cover must be used, as the worn float shaft hole will not accept the knurled float shaft press fit. A new cover can be ordered from your supplier from the following list which shows the HA Carburetor model number and the new cover assembly required.

HA Model No.	Cover No.	HA Model No.	Cover No.	HA Model No.	Cover No.
A10-5045	56-597	A10-5211	56-595	A10-5238	56-595
A10-5045-1	56-597	A10-5211-1	56-595	A10-5243	56-595
A10-5092	56-597	A10-5214	56-595	A10-5246	56-595
A10-5189	56-597	A10-5219	56-597	A10-5253	56-597
A10-5200	56-595	A10-5221	56-595	A10-5255	56-597
A10-5200-1	56-595	A10-5224	56-597	A10-5256	56-595
A10-5206-1	56-597	A10-5227	56-595	A10-5258	56-595
A10-5206-11	56-597	A10-5230	56-597	A10-5261	56-595
A10-5210	56-597	A10-5235	56-597		

After the installation of the new cover and pin, the carburetor is to be reassembled and safetied in accordance with manual procedures, a small "F" stamped on nameplate after serial number to show compliance, and a log book entry should be made.