

**Volare Carburetors, LLC**

125 Piedmont Avenue  
Gibsonville, N.C. 27249, USA  
Phone: 336-446-0002 // 0005  
Fax: 336-446-0007  
Email: [mark@volarecarbs.com](mailto:mark@volarecarbs.com)  
Website: [www.volarecarbs.com](http://www.volarecarbs.com)

**Service Bulletin: SB-8 Rev B**

Original Date: June 15<sup>th</sup>, 2009

Revision Date: March 12<sup>th</sup>, 2010

**SUBJECT – MA-4-5™, MA-5™ and MA-6™ SERIES CARBURETORS  
PUMP DISCHARGE VALVE.**

1. **Applicability:** *MA-4-5™, MA-5™ and MA-6™ series float carburetors manufactured by Volare Carburetors LLC (“Volare”), and its predecessors Precision Airmotive Corporation, Facet Aerospace Products Company, and Marvel-Schebler™ (Borg-Warner) (hereinafter “Volare”).*

2. **Reason:** According to a field report, after the installation of a spring loaded valve in one carburetor the accelerator pump output was diminished. Upon re-installation of a weighted valve, the pump resumed working normally. Volare was unable to inspect the carburetor to confirm the problem or its specific cause. However, as a result of this report and to avoid the re-occurrence of this problem, this SB is being revised to include a dimensional check of pertinent bowl features prior to installation of the valve.

3. **Background:**

Current valves are of the spring loaded type to improve sealing and reduce wear.



Antecedent valves are of the weighted free-floating design which utilized the weight of the valve alone to provide sealing

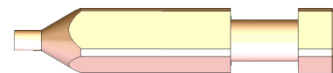

This bulletin recommends use of spring loaded valves in all MA-4-5™, MA-5™ and MA-6™ series carburetors providing that the dimension between the valve cap counter bore land and the valve seat in the carburetor bore is suitable.

4. **Compliance:** At overhaul or during the next carburetor disassembly check the dimension between the valve cap counter bore and the valve seat in the bowl and, where the dimension is sufficient, replace weighted valves with spring loaded valves and springs.

Distributed by:

**TEMPEST**  
excellence

SB-8, Revision B Issued 03/12/2010

Original Issue Date: 06/15/2009

Page 1 of 3

5. **Parts:**  
Valve, spring loaded, part number 34-91  
one per carburetor.



Spring, part number 24-A115 one per  
carburetor.



6. **Installation:** Measure the distance from the valve cap counter bore surface to the valve seat as shown in Figure 1, below. If the dimension is at least .860 inches (21.8 mm) proceed to install a spring loaded valve in accordance with the paragraphs below. If the dimension is less than .860 inches (21.8 mm) reinstall a weighted valve or contact Volare for instructions for re-machining the valve seat to obtain a suitable dimension.

6a. Install the valve spring, small end first, over the valve stem, See Figure 2. Push the spring onto the stem until it engages in the groove above the valve head. Install the valve head first into the bowl. Apply a drop of oil to the valve cap threads, install it, and tighten it to 20 -25 inch pounds.

6b. Test the accelerator pump in accordance with the appropriate carburetor service manual.

7. **Voiding of Warranty and Waiver of Liability:** Operation of a carburetor in which other than genuine Volare approved parts are installed, **voids any otherwise applicable warranty and constitutes a complete and total waiver** to the extent permitted by law of any and all rights the owner operator and/or service facility or repairer may have had to hold Volare responsible or liable for the malfunction or failure of such an aviation carburetor.

8. **Safety First:** Volare is a customer-service oriented company committed to technical innovation in pursuit of aviation safety. While Volare has no authority to compel owners to act responsibly and take prudent action to ensure their own safety and the safety of others, Volare believes compliance with this Service Bulletin is important and strongly encourages owners to comply with this Service Bulletin.

Distributed by:

**TEMPEST**  
excellence

SB-8, Revision B Issued 03/12/2010

Original Issue Date: 06/15/2009

Page 2 of 3

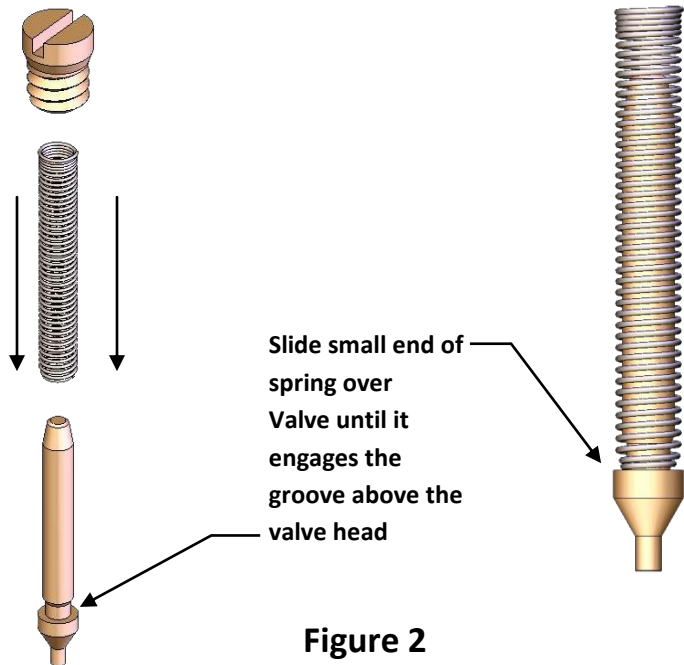

**Figure 2**

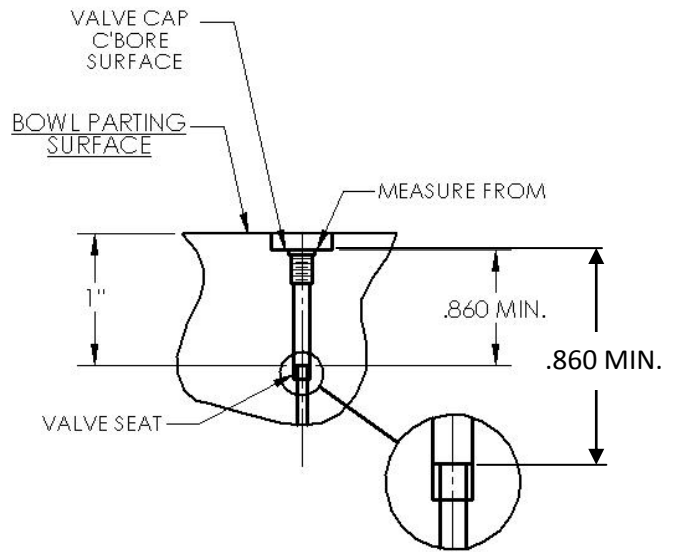
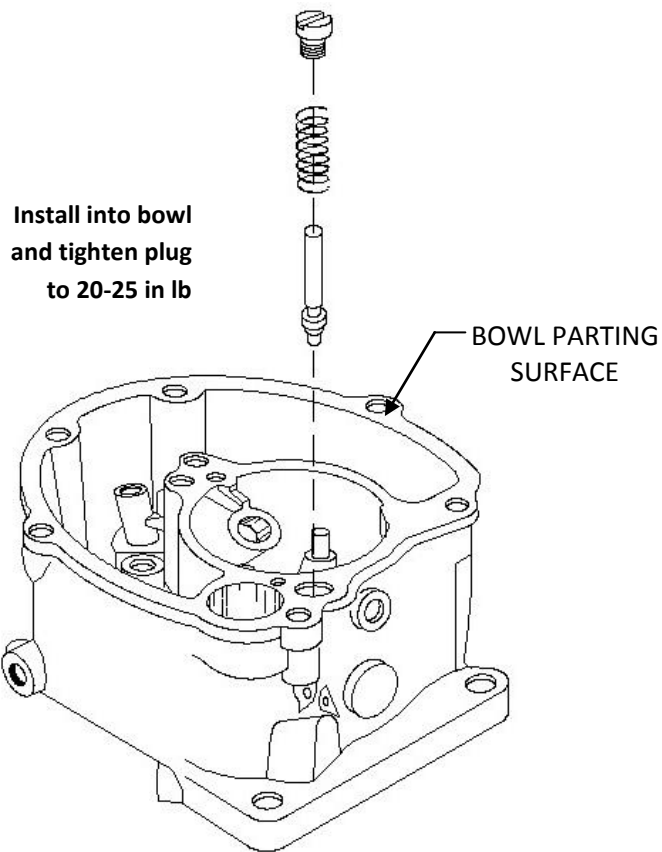

**Figure 1**

Distributed by:



SB-8, Revision B Issued 03/12/2010

Original Issue Date: 06/15/2009